

Give your homes a distinctive edge.



 **ROYAL** Garage Door Trim System

{ WINDOW & DOOR SURROUNDS • DECORATIVE MOULDING • SOFFIT, FASCIA & TRIM }



## Table of Contents

About Royal Garage Door Trim System .....	2
Garage Door Stops.....	4
Garage Door Jamb & Brick Mould .....	5
Garage Door Lite Lineals .....	6
Garage Door Overlays.....	7
Garage Organizer System .....	8
Pole & Post Surrounds.....	9
Installation Tips.....	10
Capabilities .....	14
Warranties .....	15

**R**oyal Garage Door Trim System is the energy-efficient way to seal out moisture, dirt and bugs. Enjoy the beauty and sustainability of Royal Garage Door Trim System. Made from durable 100% cellular PVC, Royal Garage Door Trim System offers 70% better insulation performance over wood and 1600% better performance than aluminum. This ready-to-install system includes never rot brick mould, jamb and garage door stop. All are prefinished, moisture resistant, termite proof and have a never rot lifetime warranty.



## Royal Garage Door Trim System

- Lifetime never rot material
- Ready to install
- Factory-applied finish
- No further painting required
- Repaintable with oil or latex
- Low maintenance
- Moisture and termite proof material
- Does not promote mold or mildew

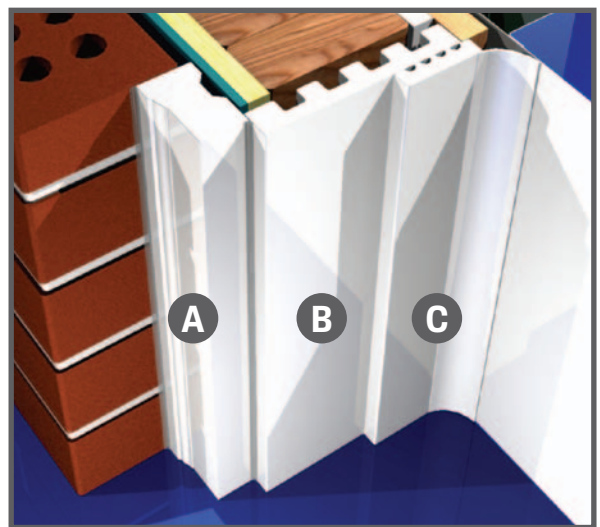
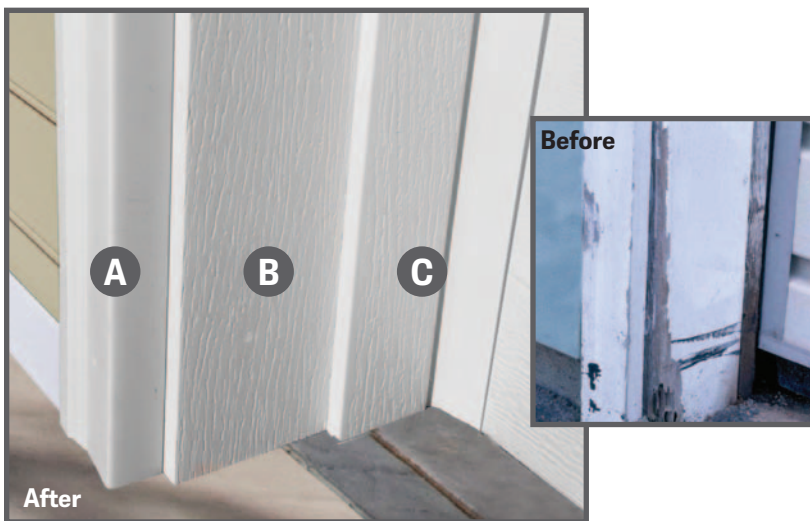

**A** Brick Mould

**B** Jamb\*

**C** Garage Door Stop

\* Jamb is non load-bearing.

# Garage Door Stop



**Garage Door Stop**  
**Mini**  
 2914  
 13/32" x 1-1/2"

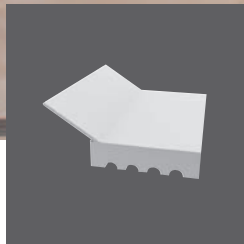

**Garage Door Stop**  
 2100  
 7/16" x 1-7/8"

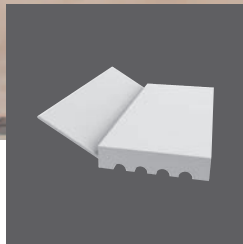

**Garage Door Stop**  
 2016  
 7/16" x 1-7/8"

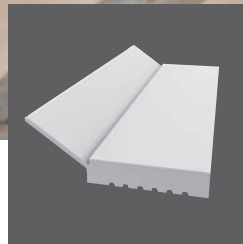

**Garage Door Stop**  
 2149  
 7/16" x 2"

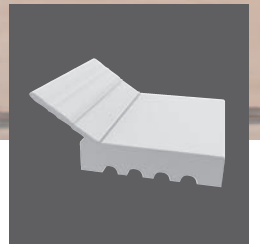

**Garage Door Stop**  
 2211  
 7/16" x 2"

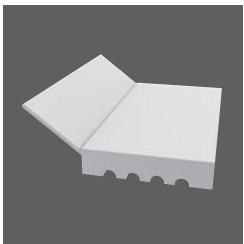

**Garage Door Stop**  
 2213  
 7/16" x 2"

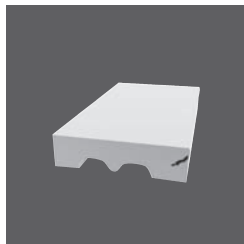

**Garage Door Stop**  
 2089  
 1/2" x 2"

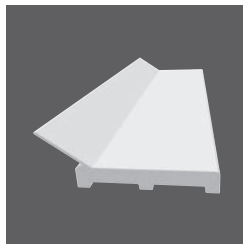

**Garage Door Stop**  
 3029  
 7/16" x 2-5/8"

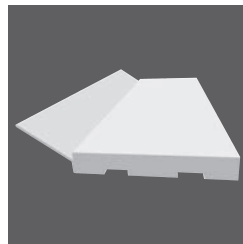

**Garage Door Stop**  
 2603  
 1/2" x 3-1/2"

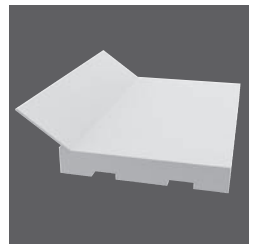

**Garage Door Stop**  
 2591  
 1/2" x 3-1/4"

## Available Colors:



White

Almond

Sandstone

Bronze

Brown

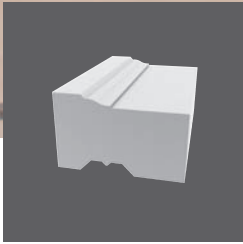

**Brick Mould**  
2448  
1-1/4" x 2"

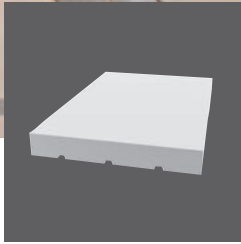

**Jamb**  
2328  
5/8" x 4-9/16"

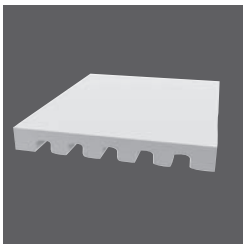

**Jamb**  
2497  
5/8" x 5-5/8"

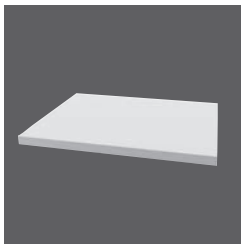

**Utility Trim**  
2709  
5/16" x 5-13/16"

- Lifetime never rot material
- Low maintenance
- Moisture and termite proof
- Dent resistant
- Reduces energy costs
- Strong and durable

**Available Colors:**



White\*



Almond



Sandstone\*



Bronze\*



Brown\*

\* Profiles 2448 and 2497 are available in white, sandstone, bronze or brown.



## Royal Garage Door Lite Lineals

- Easy to machine
- Strong and durable
- Available prefinished, paintable or stainable
- Custom color-match finish available
- Designed to complement any garage door design

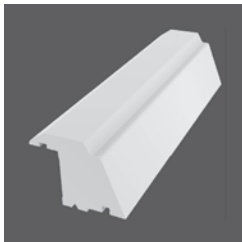

**Door Lite**  
2013  
1-1/16" x 1-3/8"



**Door Lite**  
2014  
1-1/16" x 1-3/8"



**Door Lite**  
2060  
1-1/16" x 1-3/8"



**Door Lite**  
2061  
1-1/16" x 1-1/2"

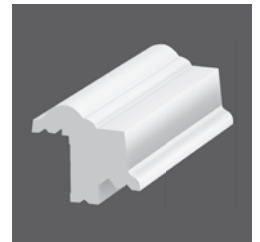

**Door Lite**  
2115  
1-7/32" x 1-7/16"



**Door Lite**  
2305  
1-5/32" x 1-15/32"



**Door Lite**  
2114  
1-1/16" x 1-3/8"



**Door Lite**  
2306  
1-5/32" x 1-15/32"

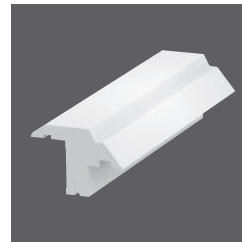

**Door Lite**  
2225  
1-1/16" x 1-3/8"



### Overlay Design Ideas

#### Design #1

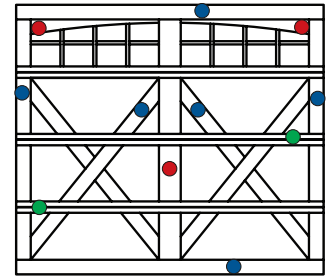

- 2150 Trimboard 1x2
- 7835 Trimboard 1x6
- 7836 Trimboard 1x8

#### Design #2

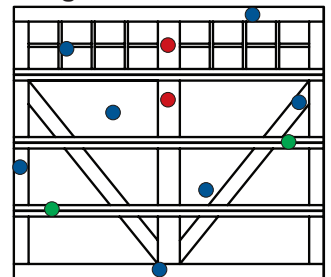

- 2150 Trimboard 1x2
- 7835 Trimboard 1x6
- 7836 Trimboard 1x8

#### Design #3

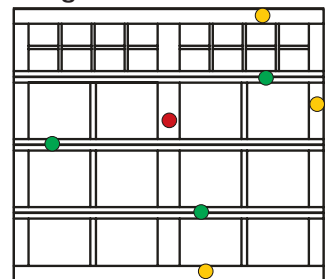

- 2150 Trimboard 1x2
- 7834 Trimboard 1x4
- 7836 Trimboard 1x8

#### Design #4

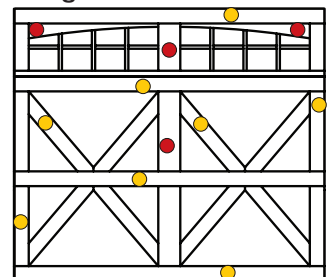

- 7834 Trimboard 1x4
- 7836 Trimboard 1x8

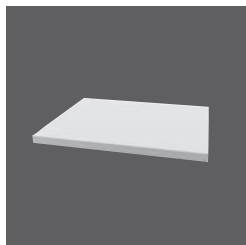

**Utility Trim**  
2709  
5/16" x 5-13/16"

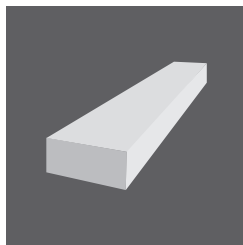

**Trimboard 5/8x2**  
2150  
5/8" x 1-1/2"



Trimboard is reversible with a woodgrain embossed texture or smooth surface.

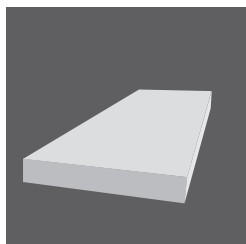

**5/8" Trimboard**

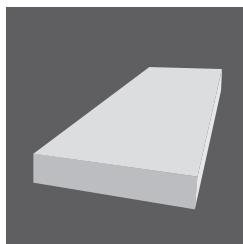

**1" Trimboard**



**5/4" Trimboard**

Item #	Nom. Width
7827	5/8" x 4"
7828	5/8" x 6"
7829	5/8" x 8"
7830	5/8" x 10"
7831	5/8" x 12"

Item #	Nom. Width
7834	1" x 4"
7835	1" x 6"
7836	1" x 8"
7837	1" x 10"

Item #	Nom. Width
7840	5/4" x 4"
7841	5/4" x 6"
7842	5/4" x 8"

Overlays finished in dark colors require special compound formulation. Dark colors are considered any color that falls within the lightness (L) value of 56 to 0 noting that 100 is white and 0 is black.

*Organize and add value to your home and start enjoying your garage once again!*



Royal's garage organizer system organizes any space while protecting walls from damage and moisture. Slat wall components interlock for versatile results and utilize standard pegboard hardware for simple low-cost storage solutions.

- 100% cellular PVC
- Strong and durable
- Low maintenance
- Easy to install
- Moisture and termite proof material
- Energy efficient
- Does not promote mold or mildew
- Expandable

GARAGE ORGANIZER SYSTEM



**Slat Wall**  
7701

9/16" x 12-5/16"

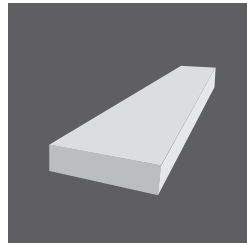

**Trimboard 1x4**  
7834

3/4" x 3-1/2"

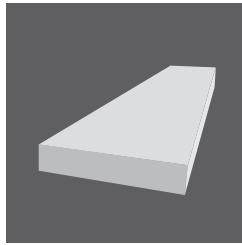

**Trimboard 1x6**  
7835

3/4" x 5-1/2"





**The beautiful solution to exterior poles and posts.**

Transform unsightly deck posts, support poles and exposed pipes into beautiful decorative columns. Royal's pole and post surround is your solution for both interior and exterior applications. This unique interlocking system snaps together in less than five minutes, with an easy-to-use kit including the surround along with top and bottom trim.

- Lifetime never rot warranty
- Prefinished, ready to install
- Unique interlocking system makes assembly a "snap"
- Quick fit top and bottom trim included in kits for decorative results

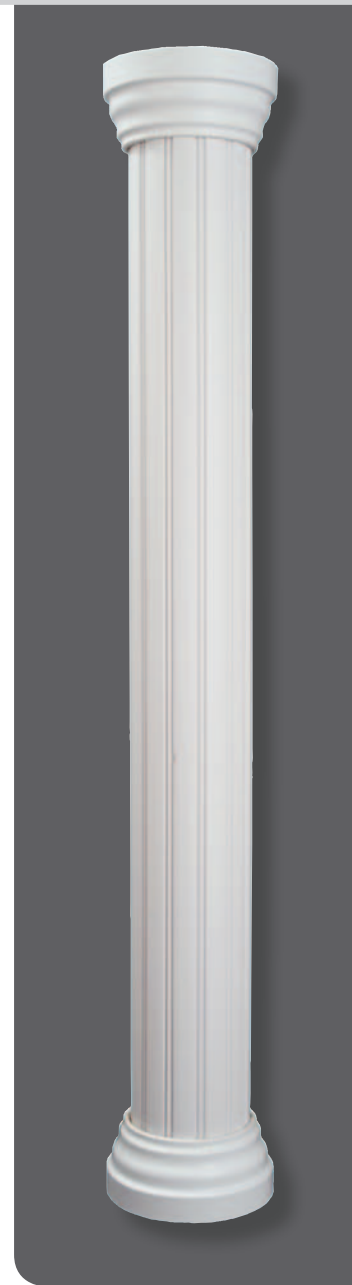

**Available Styles**

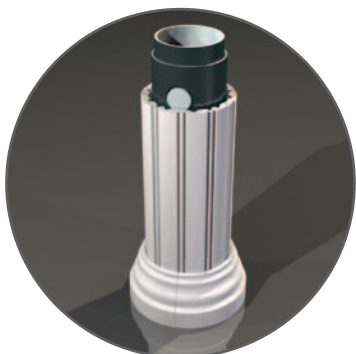

**3-1/2" Jack Post Kit**

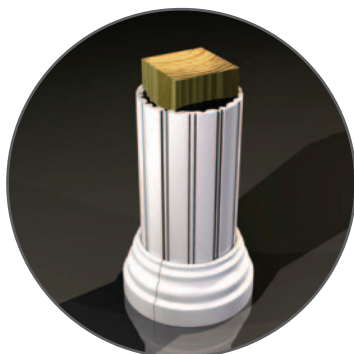

**4" x 4" Round Kit**



**6" x 6" Kit**

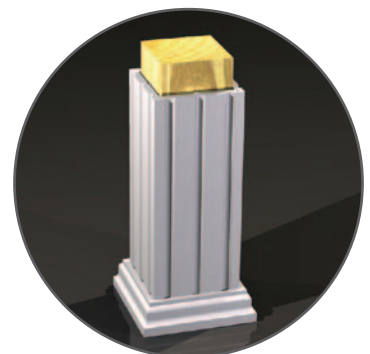

**4" x 4" Square Kit**

## Tools

- **Safety glasses and power miter saw:** carbide saw blade with 80 teeth or more recommended.
- **Miter box and hand saw:** Limited angle adjustment (not recommended for crown).
- **Coping saw:** Only needed if you choose the coping technique to install the moulding.
- **Angle gage:** To create the correct miter, you must determine the wall corner angle.
- **Glue:** To adhere the miter joints, Royal Building Products strongly recommends gluing all joints with PVC glue (also known as "pipe cement") or the OSI® TRIMTeQ™ System.
- **Hammer & nails** or a pneumatic nail gun.

Other tools may include a tape measure, pencil, C-clamp, putty and caulk.

## Nailing

Install mouldings using 6d and 8d galvanized nails and/or recommended adhesives (see chart on page 18). Place nails 12" on center. Nails should be approximately 3/4" from each edge. If nailing product at 40°F or below, pre-drilling is required. Pneumatic nailing is also recommended.

## Fastening Trim Board

Use fasteners designed for wood trim and wood siding (thinner shank, blunt head, full round head) with trim board. Use only fasteners intended for exterior use such as stainless steel or hot-dipped galvanized.

DO NOT USE staples, small brads and wire nails. The fasteners should be long enough to penetrate the solid wood substrate a minimum of 1-1/2".

Use two fasteners per every framing member for trim board applications. Trim boards 12" or wider as well as sheets will require additional fasteners. Fasteners must be installed no more than 2" from the end of each board.

Trim boards should be fastened into a flat, solid substrate. Fastening trim boards into hollow or uneven areas must be avoided. Unless product is installed in lower temperatures (< 40°F) pre-drilling is typically not required. Thinner trim products (3/8" and 1/2") are not intended to be ripped into trim pieces. They are to be glued to a substrate and mechanically fastened.

## Using TRIMTeQ to Fasten Trim Board

The OSI® TRIMTeQ™ System is specifically designed for exterior PVC trim installs.

It features innovative fastening and sealing products along with a comprehensive training program designed specifically for cellular PVC trim installation. It is formulated to maintain long lasting durability and aesthetics that home owners expect.

PVC Trim products will expand and contract with changes in temperatures. A proper installation utilizing the TRIMTeQ™ system will minimize the movement that occurs due to changes in

temperatures and help maintain a long lasting quality installation.

What products are part of the OSI® TRIMTeQ™ system?

- OSI® TRIMTeQ™ TeQ Mount™ - Fast Grab Polyurethane Mounting Adhesive
- OSI® TRIMTeQ™ TeQ Bond™ - Miter & Scarf Joint Adhesive
- OSI® TRIMTeQ™ TeQ Fasteners™ - PVC Trim Screws & Plugs featuring the Cortex® hidden fastener system
- OSI® QUAD® Advanced Formula Sealant - Finishing Sealant
- OSI® EP-1000 - Control / Expansion Joint Sealant

Next we will demonstrate how to properly install cellular PVC trim to the exterior of a home with the OSI® TRIMTeQ™ system.

1. First mount PVC Trim to the House using OSI® TRIMTeQ™ TeQ Mount™
  - a. OSI® TeQ Mount™ is a mounting adhesive specifically designed to fasten cellular PVC trim board to the exterior of a home.
  - b. It features an innovative fast grab formula with durable polyurethane strength. TeQ Mounts premium formula is water and weatherproof and will last as long as the surfaces it joins together.
  - c. Make sure all surfaces are dry and free of dust, dirt, oil and other foreign materials.
  - d. Standing surface water or ice will interfere with bonding.
  - e. Cut spout to desired bead size (1/4" recommended) and pierce inner seal.
  - f. Apply adhesive to the back of the PVC trim board.
  - g. Some manufacturers require a stop, start diagonal line pattern with a bead size of 1/4"- 3/8" diameter on to the substrate area (Figure 1).
  - h. The stop, start diagonal line pattern is designed to channel water down away from the home.
  - i. Press the PVC trim board to the exterior of the home firmly. OSI® TeQ Mount™ will bridge 3/8" gap and helps minimize the boards thermal movement (Figure 2).
  - j. OSI® TeQ Mount™ meets APA AFG-01, ASTM C-557, ASTM D-3498 and conforms to HUD UM 60a.



Figure 1

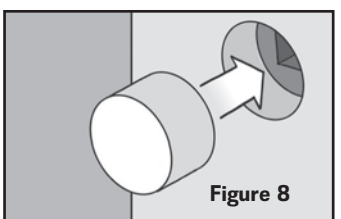
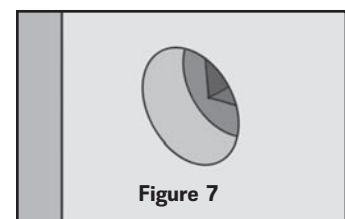
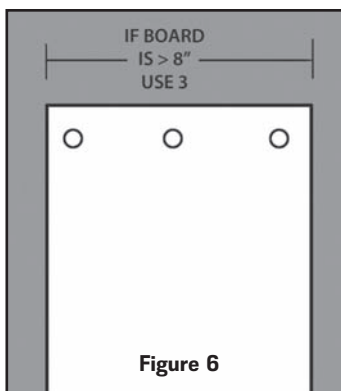
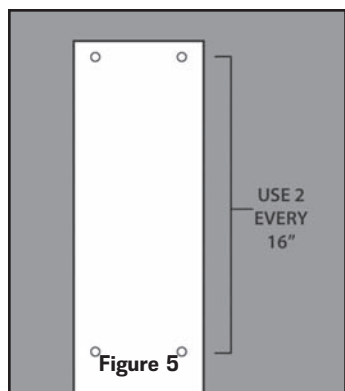
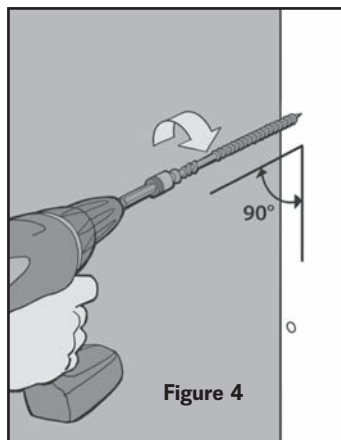

Figure 2

2. Next mechanically Fasten the PVC Trim board to the house
  - a. Use OSI® TRIMTeQ™ TeQ Fasteners™ concealed fastening system.

- b. TeQ Fasteners™ are specifically designed to fasten cellular PVC trim to the home. It features the Cortex™ concealed fastening system that is virtually invisible providing the professional finish that homeowners expect.
- c. TeQ Screws offer the highest level of connection strength while also creating a consistently cored hole for the PVC plug connection. Each TeQ Screw is coated using a proprietary coating process.
- d. The setting tool is engineered to ensure that the fasteners are set to the correct depth every time (Figure 3).
- e. Each PVC plug has been engineered to ensure ultimate long term performance against outdoor elements.
- f. Use a high voltage impact drill with the setting tool, drive the fastener to the preset level below the trim surface.
- g. The fastener must be driven perpendicular to the surface (Figure 4).

*TIP: In general, use two fasteners at every framing member at 16" on center or less. Use three fasteners if the board is wider than 8" (Figures 5 & 6).*



- 3. Setting the TeQ PVC plug
  - a. To ensure a strong bond, the cored hole must be free of dirt or rain water.
  - b. Place the plug into the hole with the trim surface side up and gently tap until flush with the trim (Figures 7 & 8).

*TIP: Be careful to ensure that the head of the hammer is flat with the trim surface to eliminate potential marring (Figs. 9 & 10).*

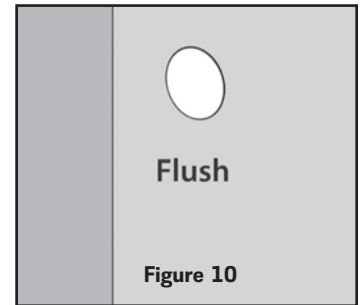
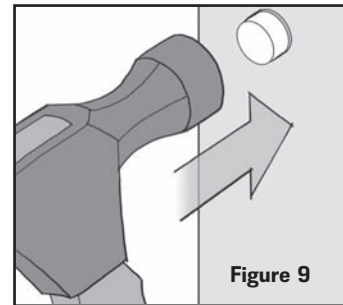

- c. Under some conditions, you may see a subtle indication that there is a doweled plug in the trim. It is recommended that you test the system on a few boards to ensure you approve the final look.

*TIP: To remove a fastener set below the trim surface, replace the setting tool in your impact driver with a #1 square drive bit, allowing full access to the seated fastener.*

- 4. Gluing a Miter or Scarf Joint
  - a. To achieve an optimum bond at the miter and scarf joint apply OSI® TRIMTeQ™ TeQ Bond™ PVC Adhesive.
  - b. TeQ Bond™ is specifically designed to adhere PVC miter and scarf joints. Its premium formula provides a permanent durable bond that prevents joint separation. The innovative formula provides UV resistance and is water and weatherproof.
  - c. Make sure all surfaces are dry and free of dust, dirt, oil and other foreign materials. Apply a small bead to one side of the joint and apply moderate pressure (Figures 11 & 12 miter joint, Figures 13 & 14 scarf joint).

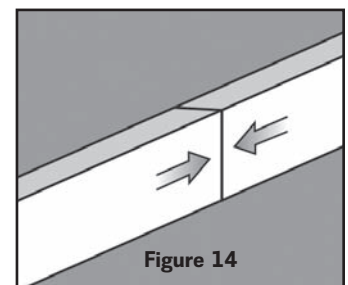
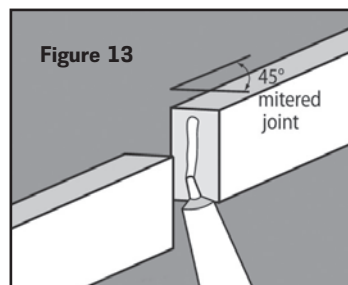
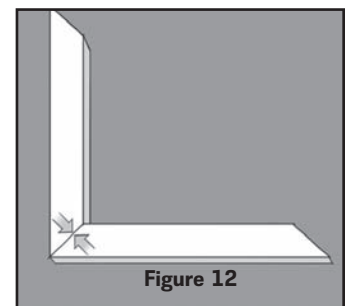
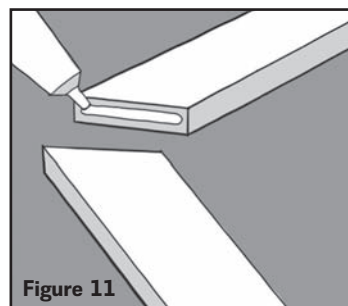

- d. The glue joint should be secured with a fastener and/or fastened to the home on each side of the joint to allow for proper contact of the boards being glued together and adequate bonding time (Figure 15).

- e. OSI® TeQ Bond has a working time of 5 minutes and will be fully cured in 24 hours.

- f. Apply OSI TeQ Mount to the back of the trim board and press firmly to the exterior of the home (follow instructions from earlier).

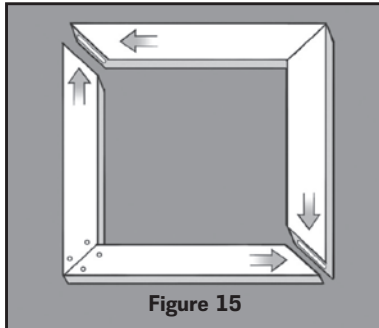

Figure 15

- g. Next, install the OSI TeQ Fasteners (follow instructions from earlier).

## 5. Finishing Sealant Instructions

- a. OSI® QUAD® Advanced Formula Sealant is recommended for all finishing applications.
- b. OSI® QUAD® is a premium all weather sealant and provides a superior long lasting durable seal.
- c. It is recommended that OSI® QUAD® be applied to the void where the trim meets the siding.
- d. Applying the right amount of sealant is the most important step when sealing gaps.
- e. To achieve the right amount cut the tip at a 70° angle.
- f. With Quad's break-away seal all you need to do is load the gun, apply pressure to the trigger and you are ready to seal.
- g. It is important that a 1/8" gap be left between the siding & trim. This allows for expansion and contraction and allows for enough room for the siding to move as the building settles.
- h. It is important to caulk with a 1/4"-3/8" rounded bead.
- i. Use a thick rounded bead to maintain the proper amount of sealant once it fully cures; because Quad naturally shrinks, tooling is neither needed or recommended (Figure 16).



Figure 16

- j. Seal all end joints; end joints are where the siding meets a piece of trim around windows, doors and corners of the house.
- k. The resulting seal will accommodate joint movement and provide superior UV resistance.

**BEST PRACTICE TIP:** Make sure to seal all gaps around exterior penetrations such as dryer vents, exterior lights, pips, electrical wires and water spigots.

## Gluing Miter Joints

Royal Building Products strongly recommend gluing all miter joints on PVC or styrene mouldings using a quality instant glue, PVC cement or OSI TeQ Bond. It may seem unconventional, but the benefits outweigh the inconvenience. When assembling splice and return miters, try gluing the mouldings together before installation.

This will allow you to fit the joints uninhibited, and fasten the trim to the wall as one unit. Fitting these joints on the wall can be difficult and possibly jeopardize the integrity of the miter joint.

## Brick Mould & Jamb Installation

1. Remove old jamb, brick mould and garage door stop with a pry bar or hammer.

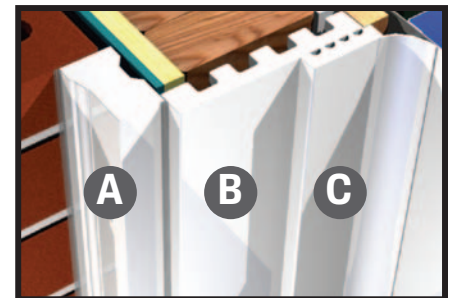

2. Measure the top opening from side to side and cut jamb to fit with a fine tooth power or hand saw.
3. Install top jamb piece using 8d galvanized finishing nails to 2x4 or 2x6 structural frame members. Alternate nailing from side to side, nailing every 12" and approximately 3/4" from each edge. Note: If nailing product at 40°F or below, pre-drilling is required.
4. Measure and cut jamb side pieces to fit from top jamb to floor. Nail as directed.
5. Measure top brick mould to overlap the jamb material by 1/2". This will allow for a 1/8"-1/4" reveal around the jamb. Reveal should be both on top and sides. Cut 45° angle on ends, butt or angle joint middle seam if needed. \*Note: Reveal may vary depending on siding, siding J-channel, brick or block installation.
6. Install brick mould using 10d or 3" galvanized finishing nails, spaced 12" on center. Use PVC cement or OSI TeQ Bond in the mitered joint for optimum fit. \* Note: nails should penetrate structural frame at least 1".
7. Measure and cut side brick mould trim to fit. Install as directed.

## Garage Door Stop Installation

1. When installing garage door stop alone, open the garage door and remove old door stop with standard claw hammer.
2. Close garage door. Begin garage door stop installation by measuring and marking 1/2" from outside of garage door several places around the jamb. Connect the marks with a straight edge, then open door again.

3. Measure top opening from side to side and cut garage door stop ends square with fine tooth power- or hand saw.
4. Place grooved side against jamb and inner edge, (where hard vinyl joins weatherstrip) along marked lines. Nail in place with 6d galvanized finishing nails in the pre-punched nail guides or 8" on center.
5. Measure and cut each piece to fit, from top piece to floor. With grooved side against jamb, position nail as directed.
6. For a good drainage and overlap, trim side stop pieces at a 45° angle with scissors where the soft vinyl weather stripping meets the top.

## Garage Organizer System Installation

Mount the system by screwing directly into the studs. Screws should be #8, minimum, in size and long enough to penetrate studs by 1/2 their length. Length may vary depending on wall construction. Join panel ends over studs to maximize load capacity.

## Painting Royal Cellular PVC

### Painting Royal Cellular PVC

Royal's factory-applied finish requires no painting for protection. Desired custom finishes can be achieved using oil based or latex paints. To maintain warranty for custom colors in darker shades, use of paints with VinylSafe™ Technology from Sherwin Williams is recommended. (Dark colors are considered any color that falls within the lightness (L) value of 56 to 0 noting that 100 is white and 0 is black.)



Trim board requires no painting for protection but can be painted with 100% acrylic latex paint to achieve custom colors. Scuff sanding will optimize paint adhesion but is not required. Apply a second coat (if required to achieve desired color).

### Touch-Up for Exterior Mouldings

- Dap® "All Purpose" Painter's Putty®
- Minwax High Performance Wood Filler®
- Elmer's Fill-N-Finish Light Wood Filler®
- Sherwin Williams Shrink Free Spackling®

After installation is complete, caulk and/or putty all gaps and nail holes.

## Cleaning Exterior Mouldings and Trim

Cleaning Royal's mouldings is easy and fast with most major household cleaners. There are many cleaners on the market, and glass cleaners seem to be the best candidate for keeping the finish intact. The cleaning solution should be applied and immediately wiped dry. With any cleaning material, the cleaning solution should not be left to stand on the components for an extended

period of time. Royal Building Products recommends the following cleaners:

- Windex®
- 409 Glass and Surface Cleaner®
- Spic & Span Cinch®
- Fantastik All-Purpose®
- Fantastik Orange Action®
- Regency® (Glass and Surface)
- Clorox Clean-Up®
- Glass Plus®
- Fantastik Oxy Power Multi-Purpose Cleaner®

### What to Avoid

Harsh cleaners with glycol ethers or ethanol type solvents and/or isopropyl alcohol soften the coating if left on for several minutes and are **not** recommended. Examples of these harmful cleaners are Goof Off®, Wal-Mart "Great Value All Purpose Cleaner®" (glycol ether), 409 General Purpose® (2-Butoxyethanol) and Greased Lightning® (glycol ether), citrus cleaners, abrasive cleaners, and solvents such as acetone, paint remover and lacquer.

## Adhesive Selection for Cellular PVC

The following brands have been laboratory tested and approved for use with Royal cellular PVC; however, individual conditions may vary and these adhesives may not perform under every circumstance. Other brands may also be suitable, but always test before using.

Int/Ext Adhesive	Bond Quality		
	Wood	Masonry	Steel
OSI® TeQ Mount™	G	G	F
Better Than Nails®	G	G	F
Liquid Nails LN-901 Heavy Duty®	G	G	-
Dow 100% Silicone®	F	-	F
Dap 230 Latex®	F	-	P
Contech PL-400®	F	-	F

Expansion and Contraction: Royal Building Products exterior PVC products, as manufactured, may expand and contract due to temperature variations. To reduce or eliminate open joints, the preferred method is the use of PVC cement (also called pipe glue) or OSI TeQ Bond. When bonded correctly with one of these adhesives, the joint becomes an integral part of the system to which it is being applied.

The information below is typical of the materials we use in extrusion and manufacture of custom components.

	Test Method	Free Foam PVC**	Celuka PVC**	Heat Modified PVC**
Density Range	In-house	.50-.60 typ	.60-.70 typ	.55-.70 typ
Coefficient of Expansion	ASTM D 696	2.9 x 10 (-)5	3.2 x 10 (-)5	3.5 x 10 (-)5
Heat Resistance(300°@30 min)	ASTM D 618A	Pass	Pass	Pass
Moisture Absorption (24 hrs)	ASTM D 570	0.83%	0.74%	0.78%
Flexural Modulus	ASTM D 790	126K	141K	134K
Deflection Temperature (66PSI)*	ASTM D 648	148.6°F	152.3°F	161.85°F
Thermal Conductivity	ASTM C 518	2.1	2.2	2.2
Screw Extraction Force(Face)^^	In-house	211	269	247
Screw Extraction Force(Edge)^^	In-house	201	286	248
Surface Hardness (Shore "D")	ASTM D 2240	53	70	72
Impact resistance	ASTM D 4726	74 in/lbs	155 in/lbs	155 in/lbs

\* No post processing of samples    \*\*Results may vary depending on density tested, sample preparation, cell structure, die flow, etc.  
 ^^ General Purpose #8 x 1-1/2" screw at 5/8" depth

## Weathering Data

Royal Building Products' waterbased exterior basecoat has been evaluated for the past 3 years for weatherability. The following report will give the protocol and results of the testing performed. Protocol for testing followed ASTM D-4329-05. The QUV machine was set to 8 hrs. UV at 60°C. and 4 hrs. condensation at 40°C. The lamps were uva-340. This set of conditions represents 16 hrs. of uv exposure and 8 hrs. of moisture per 24-hour period. The recommended test duration is 720 hrs. total time. We, at present, have approximately 22,000 hrs. total with very little color change and some chalking.

After reading initial color (Macbeth color meter) and reading exposed samples we have a delta E change of 1.503. Simultaneously, samples are on test in Miami, FL, and Whitman, AZ, at 21 months actual exposure (both locations) inspection showed no appreciable color change (average of 0.83 delta E). For clarification, delta E is a measurement of total color shift from the standard. A delta E difference of 1 unit is common in checking incoming color concentrates, etc., and visually is difficult to see.

For extruded exterior capped products Monsanto Centrex Q-485 is used. The value for white (c-1025 compounded in house to obtain correct color) cap is a delta E of 1.14 after 1,269 hours of exposure.

## Dimensional Stability (Heating & Freezing Cycles)

Overall Dimensions Before and After Thermal Cycling						
	Length		Width		Thickness	
	Before	After	Before	After	Before	After
Celuka	11.991	11.988	1.861	1.861	.851	.853
Cellular PVC	11.987	11.984	2.501	2.502	.988	.990
Pine	11.988	11.975	2.478	2.430	.335	.332

## Trim Board Allowable Tolerances

1. Variation in component length: - +3/4" - 0.0"
2. Variation in component width: ± 0.016
3. Variation in component thickness: ± 0.025
4. Variation in component edge cut: ± 1.5°
5. Density range: .55-.60
6. Shore-D hardness: 60-54

### NOTES

1. The results of this test are dependent on profile shape.
2. The Thermal Cycling Procedure is as follows: The samples are placed in an oven at 140°F for 8 hours, then returned to room temperature 68°F for 16 hours, and then placed in a freezer at -12°F for 8 hours and returned to room temperature for a minimum of 16 hours. This is repeated for a total of five (5) full cycles.

## Product Cross Reference

### Alphabetic

Brick Mould.....2448 .....5	Garage Door Stop .....2016 .....4	Jamb .....2328 .....5	Trimboard .....7834 .....7, 8
Door Lite .....2013 .....6	Garage Door Stop .....2089 .....4	Jamb .....2497 .....5	Trimboard .....7835 .....7, 8
Door Lite .....2014 .....6	Garage Door Stop .....2100 .....4	Pole & Post Surround ..... All .....9	Trimboard .....7836 .....7
Door Lite .....2060 .....6	Garage Door Stop .....2149 .....4	Slat Wall .....7701 .....8	Trimboard .....7837 .....7
Door Lite .....2061 .....6	Garage Door Stop .....2211 .....4	Trimboard .....2150 .....7	Trimboard .....7840 .....7
Door Lite .....2114 .....6	Garage Door Stop .....2213 .....4	Trimboard .....7827 .....7	Trimboard .....7841 .....7
Door Lite .....2115 .....6	Garage Door Stop .....2591 .....4	Trimboard .....7828 .....7	Trimboard .....7842 .....7
Door Lite .....2225 .....6	Garage Door Stop .....2603 .....4	Trimboard .....7829 .....7	Utility Trim.....2709 .....5, 7
Door Lite .....2305 .....6	Garage Door Stop .....2914 .....4	Trimboard .....7830 .....7	
Door Lite .....2306 .....6	Garage Door Stop .....3029 .....4	Trimboard .....7831 .....7	

Moulding & Trim Limited Warranty	
Product	Coverage
Lifetime never rot material	Lifetime
Degradation of cellular PVC profiles* (capped or finished)	25 years
Factory-applied finish* on interior or exterior	10 years
Color fade (factory applied paint)*	In compliance with ASTM D4726
Salt spray (passes)	1,000 hours
This warranty applies to the replacement of defective Royal component parts only. Any claim must be filed within 30 days of installation and subject to inspection.	
Exposure to temperatures in excess of 145° F may cause some expansion and contraction. For best results, nail and glue the product to be installed. See installation instructions.	

\* This warranty does not cover dark colors. Dark colors are considered any color that falls within the lightness (L) value of 56 to 0, where 100 is white and 0 is black.

Trim Board Limited Warranty
This warranty applies to the original purchaser only and is limited solely to the replacement of defective trim board product. The manufacturer shall not be liable for damage or failure of the trim board product as a result of any of the following: improper installation of the product or structure to which it is fastened, ice, tornado, hurricane, windstorm, fire, flood, lightning, earthquakes, physical abuse or misuse, any structural support malfunction, or Acts of God.
Any normal and ordinary weathering due to exposure to the elements will not be covered which is defined as chalking, fading, discoloration from ultraviolet light and/or extreme atmospheric conditions.
The warranty stated herein, to the original purchaser, will cover the trim board product to be free of manufacturing defects that may cause the product to swell (due to excessive moisture), corrode, rot or delaminate for a period of twenty-five years from the date of the original consumer purchase, and from an authorized dealer of Royal Products. It is the sole responsibility of the purchaser to determine the suitability of use for the product in its intended application.

Garage Door Stop Limited Warranty	
Product	Coverage
Lifetime never rot material	Lifetime
Degradation of cellular PVC profiles: (no capped or finished notations)	25 years
Color fade	Royal Building Products does not warrant garage door stop profiles against color fade. Should fading occur in the field, the product should be painted with good quality 100% acrylic paint.
Salt spray (passes)	1,000 hours
Excessive heat	Exposure to temperatures in excess of 140° F can cause expansion and contraction.

**Numeric**

2013.....6	2150.....7	2603.....4	7834..... 7, 8
2014.....6	2211.....4	2709..... 5, 7	7835..... 7, 8
2016.....4	2213.....4	2914.....4	7836.....7
2060.....6	2225.....6	3029.....4	7837.....7
2061.....6	2305.....6	7701.....8	7840.....7
2089.....4	2306.....6	7827.....7	7841.....7
2100.....4	2328.....5	7828.....7	7842.....7
2114.....6	2448.....5	7829.....7	
2115.....6	2497.....5	7830.....7	
2149.....4	2591.....4	7831.....7	



{ SOFFIT, FASCIA & TRIM • WINDOW & DOOR SURROUNDS • DECORATIVE MOULDING }

Distributed by:

Toll Free Ordering & Information .....800.368.3117  
Local & International.....276.783.8161  
Fax.....276.782.3292  
Website ..... royalbuildingproducts.com  
Hours.....8 am - 5 pm EST



 **ROYAL** Building Products

135 Bear Creek Road  
P.O. Box 610  
Marion, VA 24354

**A Georgia Gulf Company**

Siding • Trim • Accessories • Soffit • Rainware • Mouldings  
Deck • Fence • Rail • Window Profiles • Patio Door • Pipe • Fittings